

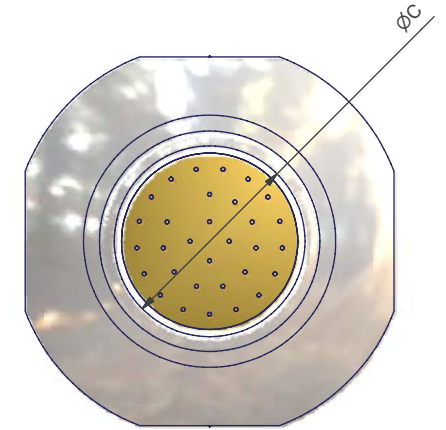

3RD ANGLE PROJECTION

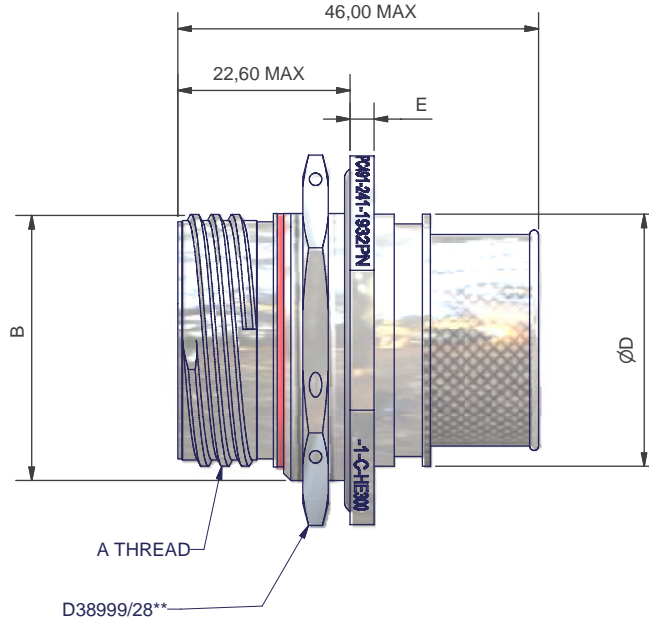

REMOVE ALL SHARP EDGES AND BURRS

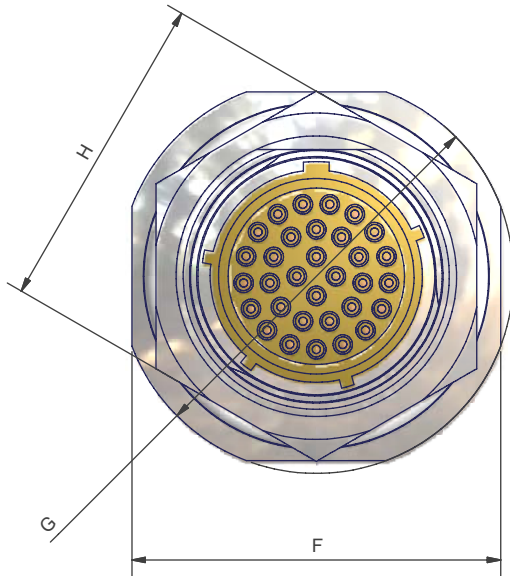

PC491-241-1932PN-1-C-HE300

SERIES _____
 STYLE _____
 ANGLE 1=STRAIGHT 3= 90 DEGREE _____
 SHELL SIZE _____
 INSERT ARRANGEMENT _____
 CONTACT STYLE P=PIN S=SOCKET _____
 ALTERNATE KEYING N,A,B,C,D,E _____
 MATERIAL _____
 PLATING _____
 SCREEN TERMINATION SB=BAND HE***=CONSTANT FORCE SPRING _____

SHELL SIZE	MS CODE	A THREAD 0.1P-0.3L-TS	B +0.1/-0.15 MAX	C MAX	D MAX	E +0.9/-0.1	F +/-0.4	G +/-0.3	H A/F	SPRING REF
09	A	0.6250	16.53	10.00	17.2	2.2	27.0	30.2	21.82/24.00	HE100
11	B	0.7500	19.07	12.70	20.3	2.2	31.8	34.9	24.99/27.00	HE200
13	C	0.8750	23.82	15.88	23.5	2.2	34.9	38.1	29.77/32.00	HE200
15	D	1.0000	26.97	19.05	26.7	2.2	38.1	41.3	32.91/36.00	HE300
17	E	1.1875	30.15	22.22	29.9	2.2	41.3	44.5	36.12/37.00	HE300
19	F	1.2500	33.32	23.80	31.5	3.0	46.0	49.2	39.25/41.00	HE300
21	G	1.3750	36.50	26.97	34.7	3.0	49.2	52.4	42.47/46.00	HE400
23	H	1.5000	39.67	30.15	37.9	3.0	52.4	55.6	45.61/50.00	HE400
25	J	1.6250	42.85	33.32	41.1	3.0	55.6	58.7	49.25/51.23	HE400

ISSUE	DCR NO.	DATE	APPROVED
1		03/02/2004	A.D.P

MATERIAL

UNLESS OTHERWISE SPECIFIED
 ALL DIMENSIONS IN MILLIMETRES
 TOLERANCE ON DIMENSIONS +/-0.1MM
 TOLERANCE ON ANGLES +/- 1 DEGREE

WEIGHT

DRAWN M.PAUL

DO NOT SCALE THIS DRAWING

THIS DRAWING IS COPYRIGHT, AND THE PROPERTY OF POLAMCO LTD. IT MUST NOT BE COPIED, USED FOR MANUFACTURE OR OTHERWISE DISCLOSED WITHOUT PRIOR WRITTEN CONSENT OF THE COMPANY.

POLAMCO LTD WESTON LOCK LOWER BRISTOL ROAD BATH BA2 1EP

TITLE 38999 SERIES 3 JAM NUT RECEPTACLE WITH INTEGRAL 91 SERIES BACKSHELL

PART NO PC491-241****

ASSY USED ON MIL-C-38999/24

DRAWING NO C0750