

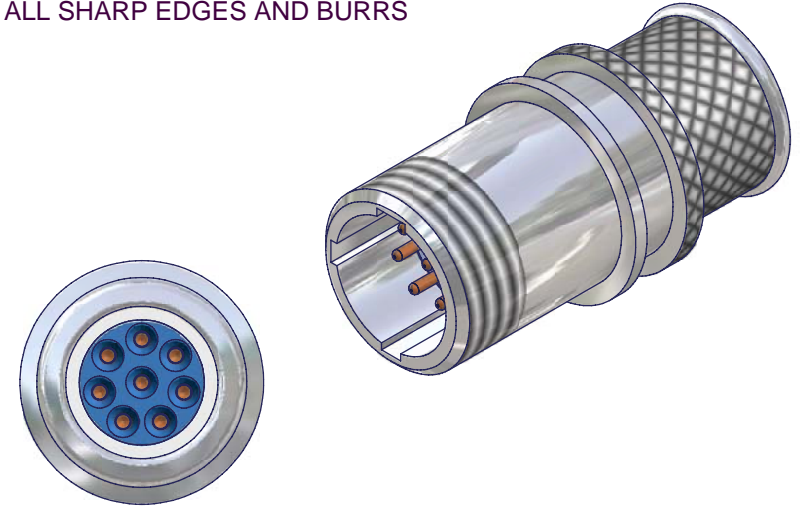

3RD ANGLE PROJECTION

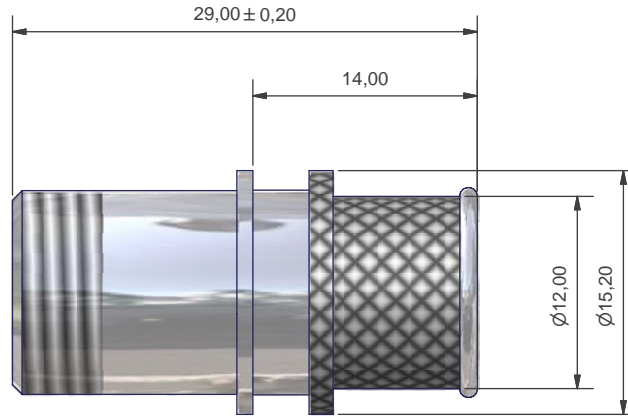

REMOVE ALL SHARP EDGES AND BURRS

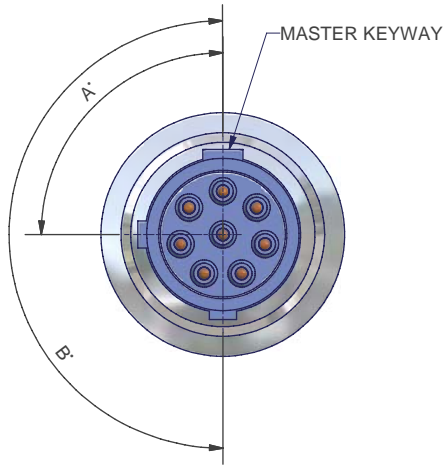

**NOTES**  
 GENERALLY TO THE REQUIREMENTS OF MIL-DTL-38999  
**MATERIAL AND FINISH**  
 SEE DATA SHEET FOR SHELL MATERIAL AND FINISH  
 ALL PARTS ROHS COMPLIANT  
**MATERIALS**  
 SEALS - SILICONE  
 CONTACTS - COPPER WITH GOLD OVER NICKEL PLATING  
 UL RATING (FLAMABILITY)  
 RIGID INSERT - V-0/5VA  
 SEALS - HB  
 POTTING - V-1

**PERFORMANCE**  
 VOLTAGE BREAKDOWN 1800V @ SEA LEVEL  
 CURRENT RATING  
 SIZE 16 13 AMPS MAX  
 SIZE 20 7 AMPS MAX  
 SIZE 22 3 AMPS MAS  
 TEMPERATURE RATING  
 -65°C TO +200°C

ALTERNATE KEYING	A DEG	B DEG
N	-	-
A	90	180
B	180	270
C	90	270

**PH1028PAC00**

SERIES \_\_\_\_\_  
 SHELL SIZE \_\_\_\_\_  
 PLAN FORM \_\_\_\_\_  
 CONTACT STYLE \_\_\_\_\_  
 ALTERNATE KEYING \_\_\_\_\_  
 MATERIAL + FINISH \_\_\_\_\_  
 MODIFIER (OPTIONAL) \_\_\_\_\_

DESIGNED AND MANUFACTURED FOR PROTECH

ISSUE	DCR NO.	DATE	APPROVED	MATERIAL	UNLESS OTHERWISE SPECIFIED ALL DIMENSIONS IN MILLIMETRES TOLERANCE ON DIMENSIONS +/-0.1MM TOLERANCE ON ANGLES +/- 1 DEGREE	DO NOT SCALE THIS DRAWING	POLAMCO LTD WESTON LOCK LOWER BRISTOL ROAD BATH BA2 1EP	PART NOPH1028*****
D		07/04/2006	P.L			THIS DRAWING IS COPYRIGHT, AND THE PROPERTY OF POLAMCO LTD. IT MUST NOT BE COPIED, USED FOR MANUFACTURE OR OTHERWISE DISCLOSED WITHOUT PRIOR WRITTEN CONSENT OF THE COMPANY.		ASSY USED ON
								DRAWING NO
								<b>C0911</b>

**POLAMCO LTD**

TITLE  
**IN LINE RECEPTACLE**